

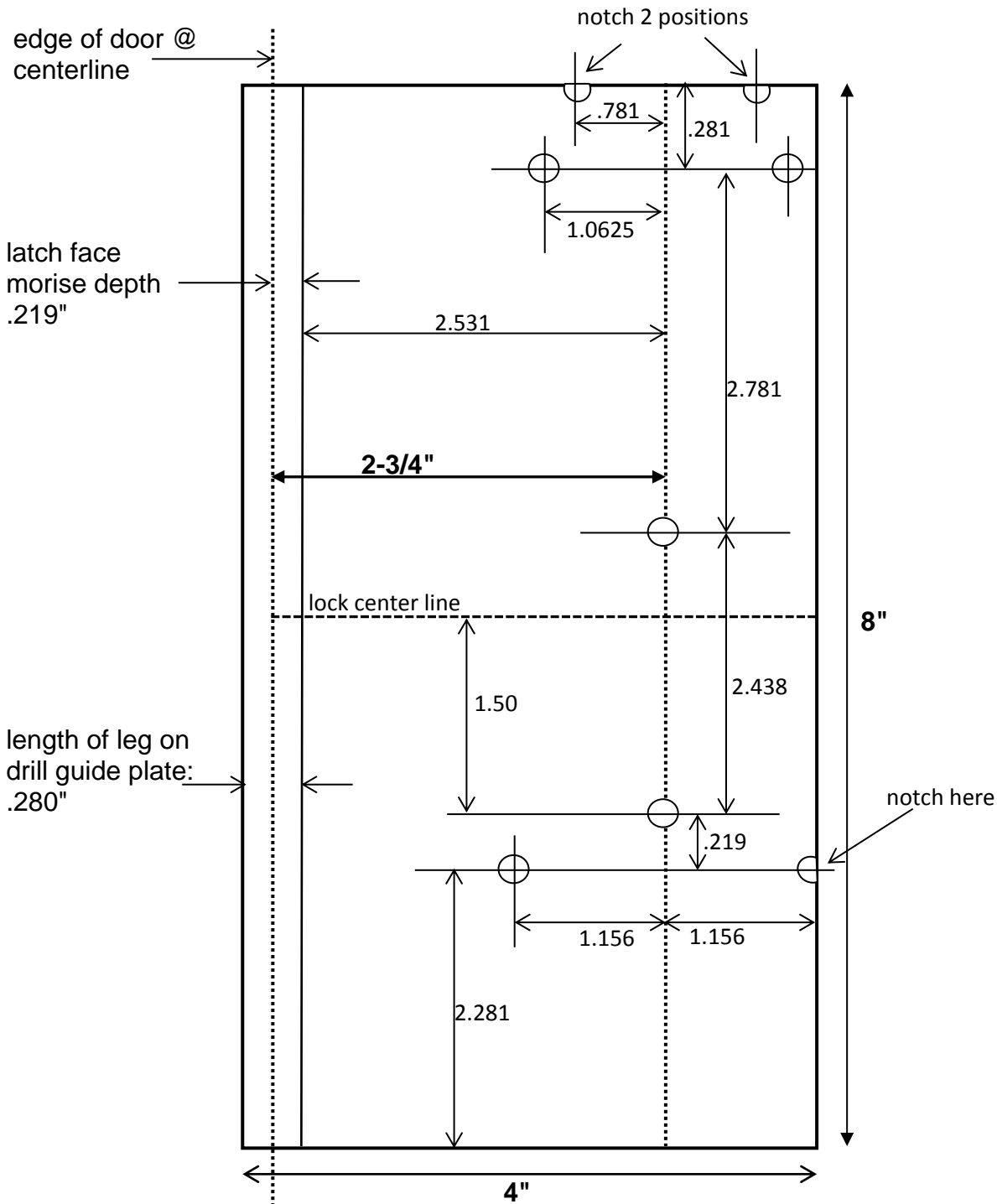

Stock Number: DG-S16

Note: Not all holes are required for all installations. Check your particular lock and installation instructions for the holes required.

**Templaco Drill Guide for Onity ILS Advance RFID ANSI
Face Template. Left & Right / Inside & Outside**



RIGHT HAND ILS RFID - ANSI DOOR FACE TEMPLATE

TOP

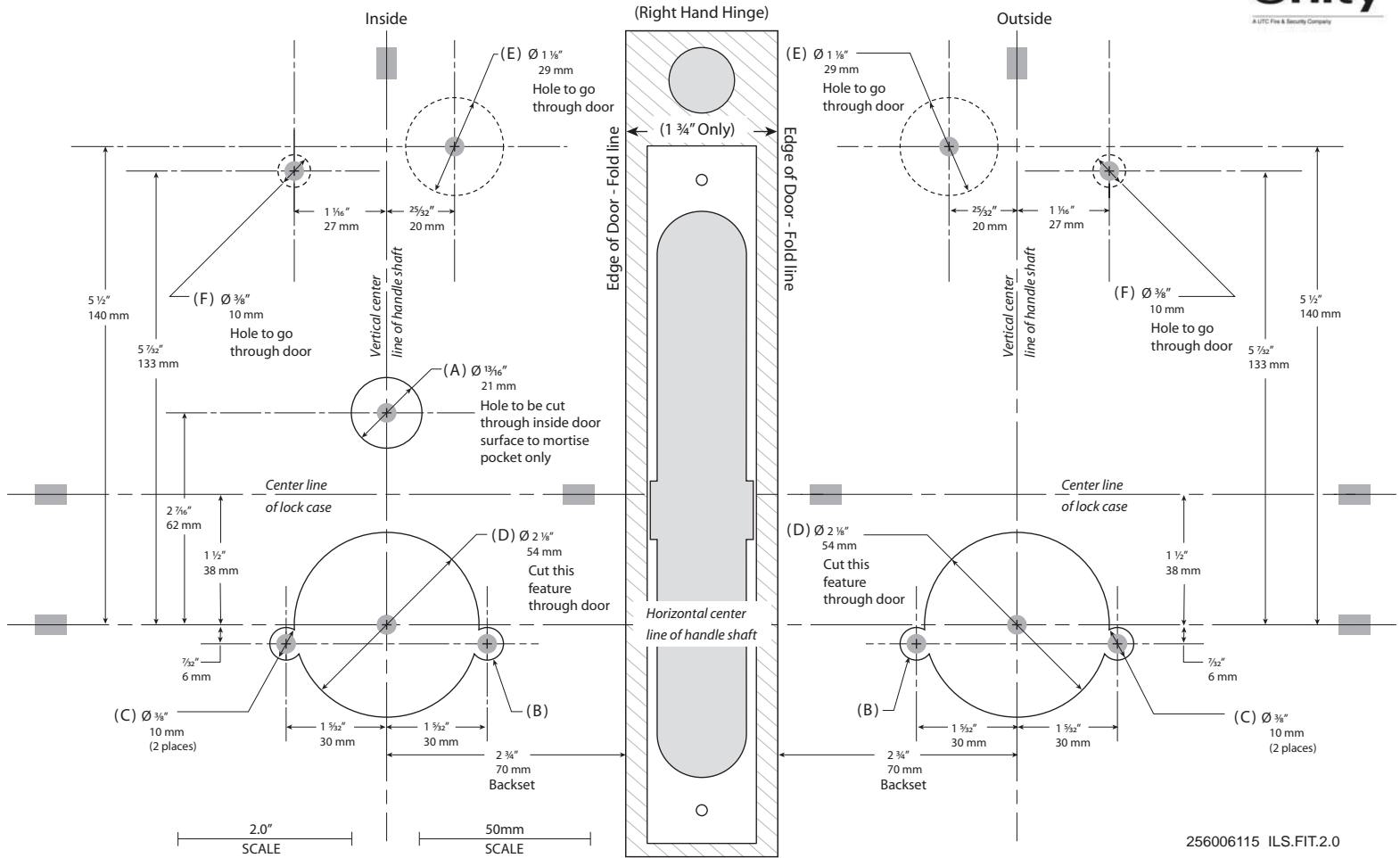

256006115 ILS.FIT.2.0

LEFT HAND ILS RFID - ANSI DOOR FACE TEMPLATE

